



**Modular Cooking Range Line
thermaline 90 - Freestanding Electric
Multi Braiser, 1/1GN, 1 Side, H=700**

ITEM # _____

MODEL # _____

NAME # _____

SIS # _____

AIA # _____



Configuration: Freestanding, One-side operated.

589266 Electric Multi Braiser, one-side operated, 1/1
(MCAA EADDAO) GN

Short Form Specification

Item No. _____

Unit constructed according to DIN 18860_2 with 20 mm drop nose top and 70 mm recessed plinth. Internal frame for heavy duty sturdiness in stainless steel. 2 mm top in 1.4301 (AISI 304). Flat surface construction, easily cleanable. THERMODUL connection system enables seamless worktop when units are connected and avoids soil penetrating. Multi-purpose cooking appliance which can be used to shallow fry, cook liquids or as a bain marie. 18 mm-thick stainless steel plated bottom, seamlessly welded to the chrome nickel steel well. Powerblock heating system for optimal temperature distribution, which can be set up to 280°C. Interior pan dimensions allows the use of GN containers. Large drain hole allows to drain the cooking juices into a large collector. All-round basin raised edges to protect against soil infiltration. Overheat protection switches off the supply in case of overheating. Standby function saves energy and quickly recovers maximum power. Metal knobs with embedded hygienic silicon "soft" grip enable easier handling and cleaning.
IPX5 water resistant certification.

APPROVAL: _____



Main Features

- Large drain hole on cooking surface permits the draining of residual cooking juices into a large collector placed under the cooking surface.
- Multi purpose cooking appliance that can be used to shallow fry, cook liquids or even as a bain marie. Unit can be used for sautéing, poaching, steaming, simmering, stewing, braising, boiling and preparing white sauces.
- Overheat protection: the temperature sensor switches off the supply in case of overheating.
- All major components may be easily accessed from the front.
- THERMODUL connection system creates a seamless work top when units are connected to each other thus avoiding soil penetrating vital components and facilitating the removal of units in case of replacement or service.
- Metal knobs with embedded hygienic "soft-touch" grip for easier handling and cleaning. The special design of the controls prevents infiltration of liquids or soil into vital components.
- Powerblock heating system for optimal temperature distribution.
- Handles are ergonomically designed with silicon "soft" grip for easy handling and cleaning.
- Raised edge all around the well to protect from infiltration of dirt from worktop.
- Temperature can be set up to a maximum of 280 °C.
- Interior dimensions of the well enables the use of GN containers.
- Large visible digital display manufactured in tempered glass to resist heat and chemicals, showing temperatures or power settings. The display also shows on/off status of the appliance and on/off status of the heating elements.

Construction

- An 18 mm thick stainless steel plated bottom is seamlessly welded into the chrome nickel steel well.
- Rounded corners and edges aid cleaning.
- Storage space in the base of the appliance that can accept GN1/1 containers.
- 2 mm top in 1.4301 (AISI 304).
- IPX5 water resistance certification.
- Unit constructed according to DIN 18860_2 with 20 mm drop nose top and 70 mm recessed plinth.
- Flat surface construction with minimal hidden areas to easily clean all surfaces
- Internal frame for heavy duty sturdiness in stainless steel.

Sustainability

- Standby function for energy saving and fast recovery of maximum power.

Optional Accessories

- Lid for multi braisers, 1/1 GN PNC 910625
- Connecting rail kit, 900mm PNC 912502
- Stainless steel side panel, 900x700mm, freestanding PNC 912512
- Portioning shelf, 400mm width PNC 912522
- Portioning shelf, 400mm width PNC 912552
- Folding shelf, 300x900mm PNC 912581

- Folding shelf, 400x900mm PNC 912582
- Fixed side shelf, 200x900mm PNC 912589
- Fixed side shelf, 300x900mm PNC 912590
- Fixed side shelf, 400x900mm PNC 912591
- Stainless steel front kicking strip, 400mm width PNC 912630
- Stainless steel side kicking strip left and right, freestanding, 900mm width PNC 912657
- Stainless steel side kicking strip left and right, back-to-back, 1810mm width PNC 912663
- Stainless steel plinth, freestanding, 400mm width PNC 912954
- Connecting rail kit: modular 90 (on the left) to ProThermetic tilting (on the right), ProThermetic stationary (on the left) to ProThermetic tilting (on the right) PNC 912975
- Connecting rail kit: modular 80 (on the right) to ProThermetic tilting (on the left), ProThermetic stationary (on the right) to ProThermetic tilting (on the left) PNC 912976
- Endrail kit, flush-fitting, left PNC 913111
- Endrail kit, flush-fitting, right PNC 913112
- Scraper for smooth plates PNC 913119
- Blades with rounded sides for scraper PNC 913123
- Endrail kit (12.5mm) for thermaline 90 units, left PNC 913202
- Endrail kit (12.5mm) for thermaline 90 units, right PNC 913203
- Stainless steel side panel, left, H=700 PNC 913222
- Stainless steel side panel, right, H=700 PNC 913223
- T-connection rail for back-to-back installations without backsplash (to be ordered as S-code) PNC 913227
- Bottom plate for multibraiser 1/1 GN PNC 913228
- Insert profile d=900 PNC 913232
- Perforated shelf for warming cabinets and cupboard bases (one-side operated TL80-85-90 and two-side operated for TL80) PNC 913233
- Energy optimizer kit 14A - factory fitted PNC 913244
- Endrail kit, (12.5mm), for back-to-back installation, left PNC 913251
- Endrail kit, (12.5mm), for back-to-back installation, right PNC 913252
- Endrail kit, flush-fitting, for back-to-back installation, left PNC 913255
- Endrail kit, flush-fitting, for back-to-back installation, right PNC 913256
- Side reinforced panel only in combination with side shelf, for freestanding units PNC 913260
- Side reinforced panel only in combination with side shelf, for back-to-back installations, left PNC 913275
- Side reinforced panel only in combination with side shelf, for back-to-back installation, right PNC 913276
- Shelf fixation for TL80-85-90 one-side operated, TL80 two-side operated PNC 913279
- Filter W=400mm PNC 913663

- Stainless steel dividing panel, 900x700mm, (it should only be used between Electrolux Professional thermaline Modular 90 and thermaline C90) PNC 913672
- Stainless steel side panel, 900x700mm, flush-fitting (it should only be used against the wall, against a niche and in between Electrolux Professional thermaline and ProThermetic appliances and external appliances - provided that these have at least the same dimensions) PNC 913688

Recommended Detergents

- C41 HI-TEMP RAPID DEGREASER, 1 pack of six 1 lt. bottles (trigger incl.) PNC 0S2292

Front

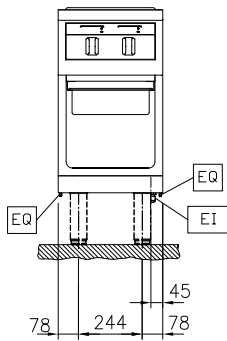

Side

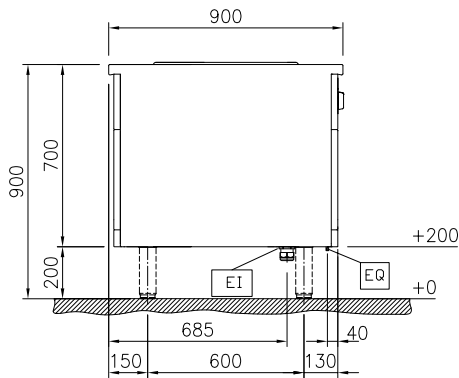

EI = Electrical inlet (power)
EQ = Equipotential screw

Top

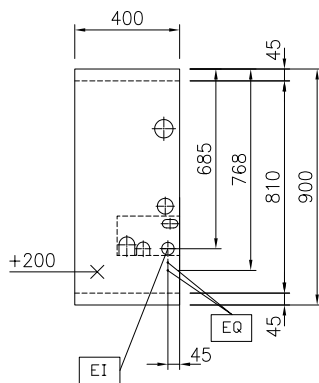

Electric

Supply voltage: 400 V/3N ph/50/60 Hz
Total Watts: 5 kW

Key Information:

Usable well dimensions (width): 306 mm
Usable well dimensions (height): 110 mm
Usable well dimensions (depth): 510 mm
Cooking Well Height: 110 mm
Well Capacity, Max: ISO 9001; ISO 14001 lt
Working Temperature MIN: 120 °C
Working Temperature MAX: 280 °C
External dimensions, Width: 400 mm
External dimensions, Depth: 900 mm
External dimensions, Height: 700 mm
Storage Cavity Dimensions (width): 340 mm
Storage Cavity Dimensions (height): 330 mm
Storage Cavity Dimensions (depth): 740 mm
Net weight: 75 kg
Configuration: Rectangular;Fixed

Sustainability

Current consumption: 7.22 Amps

Optional Accessories

- Lid for multi braisers, 1/1 GN PNC 910625
- Connecting rail kit, 900mm PNC 912502
- Stainless steel side panel, 900x700mm, freestanding PNC 912512
- Portioning shelf, 400mm width PNC 912522
- Portioning shelf, 400mm width PNC 912552
- Folding shelf, 300x900mm PNC 912581
- Folding shelf, 400x900mm PNC 912582
- Fixed side shelf, 200x900mm PNC 912589
- Fixed side shelf, 300x900mm PNC 912590
- Fixed side shelf, 400x900mm PNC 912591
- Stainless steel front kicking strip, 400mm width PNC 912630
- Stainless steel side kicking strip left and right, freestanding, 900mm width PNC 912657
- Stainless steel side kicking strip left and right, back-to-back, 1810mm width PNC 912663
- Stainless steel plinth, freestanding, 400mm width PNC 912954
- Connecting rail kit: modular 90 (on the left) to ProThermetic tilting (on the right), ProThermetic stationary (on the left) to ProThermetic tilting (on the right) PNC 912975
- Connecting rail kit: modular 80 (on the right) to ProThermetic tilting (on the left), ProThermetic stationary (on the right) to ProThermetic tilting (on the left) PNC 912976
- Endrail kit, flush-fitting, left PNC 913111
- Endrail kit, flush-fitting, right PNC 913112
- Scraper for smooth plates PNC 913119
- Blades with rounded sides for scraper PNC 913123
- Endrail kit (12.5mm) for thermaline 90 units, left PNC 913202
- Endrail kit (12.5mm) for thermaline 90 units, right PNC 913203
- Stainless steel side panel, left, H=700 PNC 913222
- Stainless steel side panel, right, H=700 PNC 913223
- T-connection rail for back-to-back installations without backsplash (to be ordered as S-code) PNC 913227
- Bottom plate for multibraiser 1/1 GN PNC 913228
- Insert profile d=900 PNC 913232
- Perforated shelf for warming cabinets and cupboard bases (one-side operated TL80-85-90 and two-side operated for TL80) PNC 913233
- Energy optimizer kit 14A - factory fitted PNC 913244
- Endrail kit, (12.5mm), for back-to-back installation, left PNC 913251
- Endrail kit, (12.5mm), for back-to-back installation, right PNC 913252
- Endrail kit, flush-fitting, for back-to-back installation, left PNC 913255
- Endrail kit, flush-fitting, for back-to-back installation, right PNC 913256

- Side reinforced panel only in combination with side shelf, for freestanding units PNC 913260
- Side reinforced panel only in combination with side shelf, for back-to-back installations, left PNC 913275
- Side reinforced panel only in combination with side shelf, for back-to-back installation, right PNC 913276
- Shelf fixation for TL80-85-90 one-side operated, TL80 two-side operated PNC 913279
- Filter W=400mm PNC 913663
- Stainless steel dividing panel, 900x700mm, (it should only be used between Electrolux Professional thermaline Modular 90 and thermaline C90) PNC 913672
- Stainless steel side panel, 900x700mm, flush-fitting (it should only be used against the wall, against a niche and in between Electrolux Professional thermaline and ProThermetic appliances and external appliances - provided that these have at least the same dimensions) PNC 913688

Recommended Detergents

- C41 HI-TEMP RAPID DEGREASER, 1 pack of six 1 lt. bottles (trigger incl.) PNC 0S2292